

Digital Outdoor Visit Panel

Instructions

Before using this device, please read this manual and properly stored it for future reference

9800158 PDK-20002

Content

1. The basic structure of the outdoor visit panel	
1). The instruction for appearance and function module	1
2). The basic interface type of outdoor visit panel	2
3). The description for basic interface of outdoor visit panel	3
2. Introduction of the outdoor visit panel	
1). Installation of the outdoor visit panel	3
2). Introduction of the basic functions	3
3. The instruction of common functions for the outdoor visit panel	
1). Intercom calling	3
2). System monitoring	4
3). System unlock	4
4). Leave message / Video record	4
5). Access IC cards function	4
4. The configuration instructions of outdoor visit panel	5

1. The basic structure of the outdoor visit panel

1). The instruction for appearance and function module

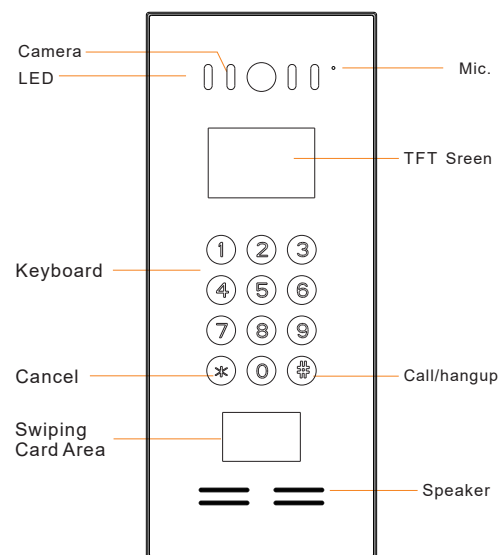

2). The basic interface type of outdoor visit panel

- The power interface
- The network interface
- The unlock interface

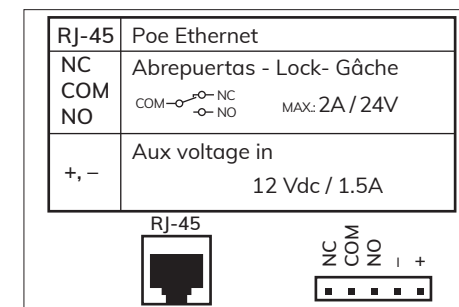

The wiring diagram

3). The description of basic interface for the outdoor visit panel

- The power interface: Auxiliary voltage in 12Vdc 1.5A
- The unlock interface: The internal relay contact
COM: Common; **NO:** Normally Open
NC: Normally Closed
- RJ-45 Poe Network interface

3. The instruction of common functions for the outdoor visit panel

1). Intercom calling

Push any button make a call

Call concierge center: Enter "0" and dial  to call concierge center.

Call residents: Dial resident room no. to call, eg. Dial "0101" and then dial  to call no. 0101 room.

Call response: It will ringing after the call succeeded, otherwise it will prompt failure

Answer: After connect to the concierge center, voice will prompt answering, then the system will stop ringing.

Message leave: When calling, long press "0" to leave message.

Calling hang up: press the  button to hang up.

Image transmission: After the call succeeded, the outdoor visit panel will transfer images to the concierge center.

Overtime hang up:

- 1) if 30 sec no answer, the system would hang up.
- 2) Talking for 3 minutes the system would hang up and there is countdown prompt.

2. Introduction of the outdoor visit panel

1). Installation of the outdoor visit panel

Flush install with the embedded box

2). Introduction of the basic functions:

- Intercom calling
- System monitoring
- Message leave
- IC card entrance guard system

2). System monitoring

- The indoor machine and concierge center can monitor the outdoor visit panel and the outdoor panel will transfer video to the indoor machine or concierge center.
- Indoor machine and concierge center answering the outdoor visit panel, it can transmit the audio data.
- Outdoor visit panel can response the hang up command from the indoor machine or concierge center.

3). System unlock

- **Unlock under monitoring:** when the outdoor visit panel is in a state of monitored intercom, when the monitoring indoor machine or concierge center proceed the unlock operation, the door phone unit will have corresponding unlock actions.
- **Call and unlock:** When the outdoor visit panel called the indoor machine or concierge center, and received the unlock command, it will respond to unlock actions.
- **IC cards unlock:** When swiping the authorised IC card, the outdoor visit panel will have corresponding unlock actions, and user will hear a sound and the relay actions.

4). Leave message / Video record

When visitor calling but no answering, the visitor long press "0" to leave message to the resident. Each of the message is 30 sec. the system would exit when overtime.

5). Access IC cards function

Notice: Before use the IC card function, please down load the configured data from management center.

Swiping card and unlock: with prompt voice when the outdoor phone read the IC card. Buzzing one time means unlock success, twice means fail.

Support card types: IC card

Card Status indicate: The system could recognize the IC card by the registered information, and indicate the relevant prompt message.

Swiping card successfully: only the registered IC card can swiping card and unlock successfully.

4. The configuration instructions of outdoor visit panel

When system startup, allocate according to the factory default IP address, if's IP address can be configured Manually: Press "00000000" to enter the system setting menu of the outdoor panel with the password: "111111", Enter the local setting menu and modify the local IP Address.